

VANDAL PROOF IP66 LED EMERGENCY BATTEN BVP20EM-1200

PowerCraft
AUSTRALIA



- Tough vandal proof IP66 emergency LED batten.
- Integral driver with dimming & control options available.
- Torx security screws
- Motion sensor options available.

Product Information

Part Number	BVP20EM-1200
Delivered Lumens +/-5%	2130lm
Power	20W
UGR	n/a
IP Rating	IP66
IK Rating	IK10
IC rating	n/a
Warranty	3 Years
LED Type	SMD
CCT	4K
CRI	80
Beam Angle	120°
Colour Stability (SDCM)	5 step Macadam Ellipse
Led Rated Lifetime L70 @25°	>100000hrs
Driver	Integral
Mains Supply	220-240V, 50/60Hz
Driver output Voltage	DC36V
Power Factor	0.09
LED Current (nominal)	500mA
Operating Temperature	0-40°C
Body Material	Diecast aluminium
Diffuser Material	Polycarbonate
Product Finish	Powder coated
Colours	Grey
Total Weight	4.5kg

Dimensions

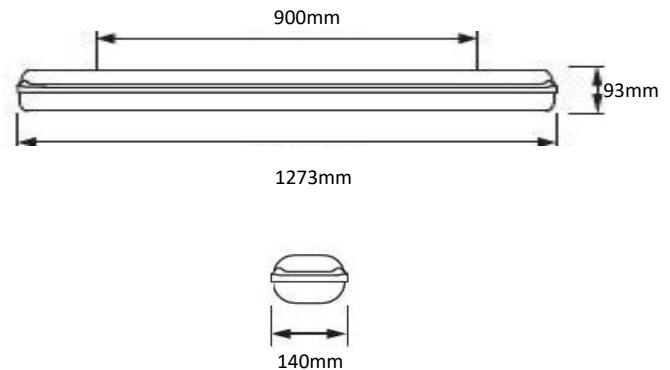

Operating mode Maintained
Battery NiCd

Luminaire Classification	2.1m	2.4m	2.7m	3.0m	3.3m	3.6m	4.0m	4.5m	5.0m
C0 - D50	11.5	13.2	14.8	16.5	18.1	19.8	21.8	22.5	23.1
C90 - D32	11.5	13.2	14.8	16.5	17.6	18	18.5	19	19.5

Sensor options BVP20EM-1200- MS motion sensor on/off
BVP20EM-1200-SD step dim 100/20%

Microwave motion sensor MC076S

